



We've made a handy video version of this fitting guide, just click the play button to view it.

If you prefer to print the instructions or simply to follow step-by-step, just keep reading.

## Fitting the brackets

1

The brackets offer two methods of installation:

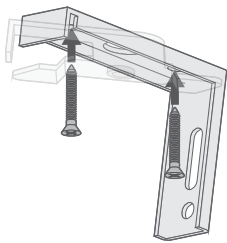

### Top-Fixing

Where the brackets are screwed into the lintel (or 'ceiling' of the recess)

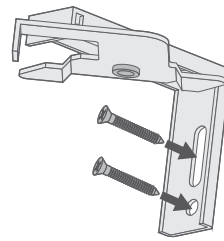

### Face-Fixing

Where the brackets are screwed onto a facing surface (a wall or window frame)

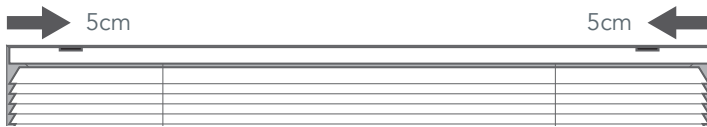

The outermost brackets should be mounted at least 5cm in from the ends of the blind.

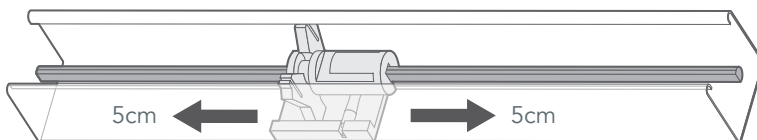

The remainder of the brackets should be spaced evenly along the width of the blind, ensuring that they do not interfere with any of the moving components in the headrail.

**Fitting the blind**

**2**

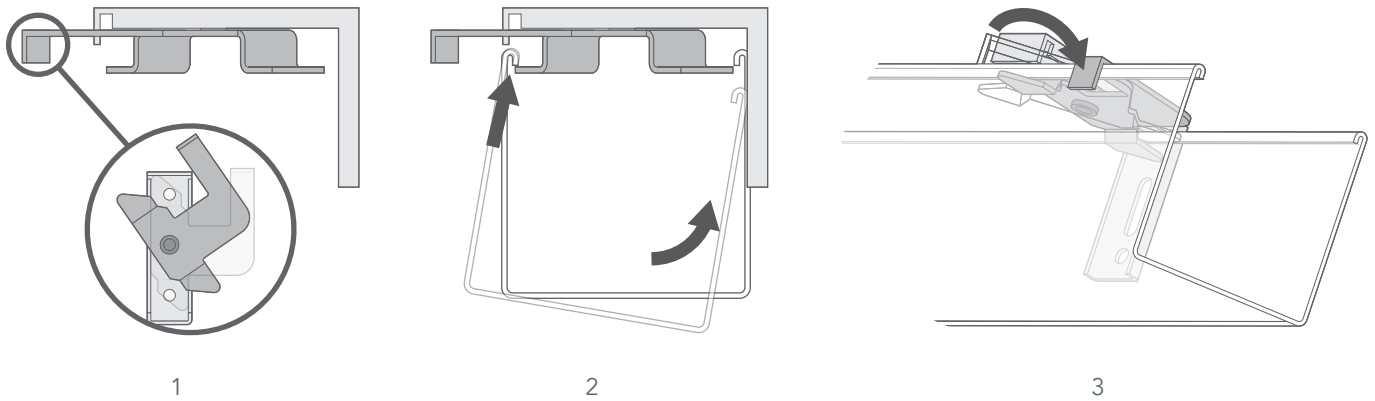

1. Turn the swivel arm on the bracket to its 'open' position; when open, the swivel part of the bracket will be sitting at a 45 degree angle to the fixed part of the bracket.
2. Rest the front lip of the headrail against the front lip of the bracket, then raise the back of the blind so that the headrail is level.
3. Push the swivel arm back so that it's sitting flush with the headrail, this will lock the headrail into the bracket.

**Top Tip**

If you pull the cords to tilt the blind but the slats do not move:

- Make sure the slats are open and that the tilt cords are both the same length.
- Stack the blind up tightly and lock it off, then take it down from the brackets.
- Push the metal rod inside the headrail all the way over to the left, so that it is connected to the tilting mechanism.

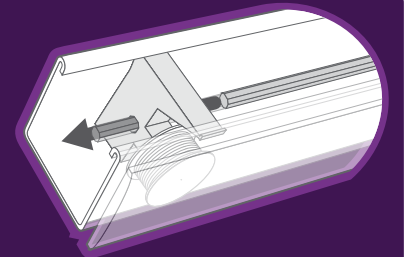

## Child Safety

### Cord Condenser

A breakaway cord condenser is pre-fitted to the lift cords so that when a horizontal force is applied to the cords above the condenser, it safely breaks away, eliminating any hazardous loops.

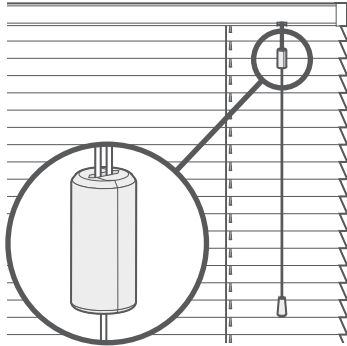

#### If the cord condenser is pulled apart:

Untwist the cords so that they're nice and straight.

Slot the cords into the channel in the centre of one half of the condenser. If your condenser differs slightly from the diagram, don't worry, just slot any cords that aren't already tied into place inside in the same way.

Click the two halves back together, ensuring there is no loose thread trapped at the edges of the condenser.

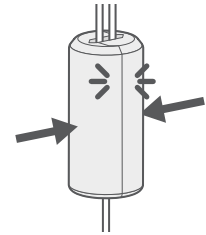
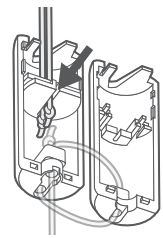

#### Top Tip

The design of the condenser can vary, so don't worry if yours doesn't look exactly like the illustration. Both designs do the same job and clip back together in the same way.

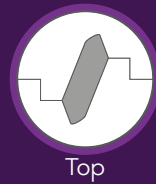

### Cord Safety Cleat

The safety cleat shall be installed as close to the headrail as possible and in all cases not less than 1500mm from the floor. The cord must be fully accumulated around the safety cleat(s) when the blind is not in use. Use the table below to determine the distance required between the cleats to fully accumulate the cords when the blind is fully raised.

Drop of blind	*Distance between cord cleats (centre to centre)
1-1000mm	100mm
1001-2000mm	150mm
2001-3000mm	300mm

Place the safety cleat in the desired position on the wall and mark the positions of the holes with a pencil.

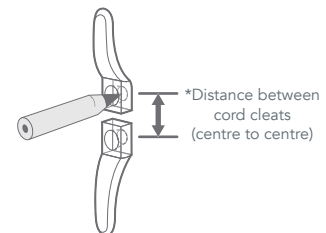

Mark the hole positions and drill as required. Use the screws provided to attach the safety cleat to the wall.

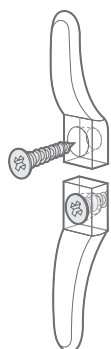

Wrap the cords around the cord cleats in a figure of 8. When the cords are fully accumulated, ensure they are secure so that when any cord is pulled, no excess cord is released.

